

## NPN General Purpose Amplifier

## BCW65/66

### FEATURES

- For general AF applications.
- High current gain.
- Low collector-emitter saturation voltage.
- Complementary types:BCW67,BCW68(PNP)



Lead-free

### APPLICATIONS

- General purpose medium power amplifier.
- Switching application.

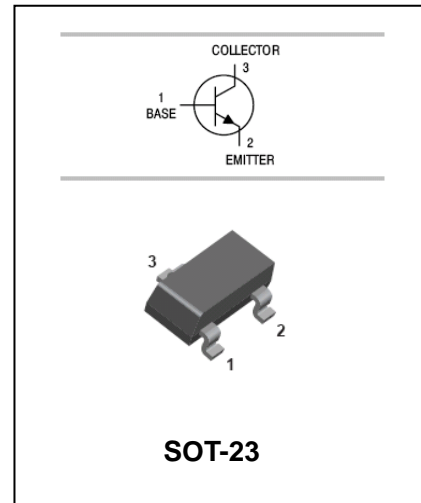

### ORDERING INFORMATION

Type No.	Marking	Package Code
BCW65A/B/C	EA/EB/EC	SOT-23
BCW66F/G/H	EF/EG/EH	SOT-23

### MAXIMUM RATING @ Ta=25°C unless otherwise specified

Symbol	Parameter	BCW65	BCW66	Unit
$V_{CEO}$	Collector-Emitter Voltage	32	45	V
$V_{CBO}$	Collector-Base Voltage	60	75	V
$V_{EBO}$	Emitter-Base Voltage	5	5	V
$I_C$	Collector Current -Continuous	800		mA
$P_C$	Collector Dissipation	330		mW
$T_j, T_{stg}$	Junction and Storage Temperature	-65 to +150		°C



**NPN General Purpose Amplifier**

**BCW65/66**

**ELECTRICAL CHARACTERISTICS @ Ta=25°C unless otherwise specified**

Parameter	Symbol	Test conditions	MIN	MAX	UNIT
Collector-base breakdown voltage BCW65 BCW66	$V_{(BR)CBO}$	$I_C=10\mu A$ $I_E=0$	60 75		V
Collector-emitter breakdown voltage BCW65 BCW66	$V_{(BR)CEO}$	$I_C=10mA$ $I_B=0$	32 45		V
Emitter-base breakdown voltage	$V_{(BR)EBO}$	$I_E=10\mu A$ $I_C=0$	5		V
Collector cut-off current BCW65 BCW66	$I_{CBO}$	$V_{CB}=32V$ $I_E=0$ $V_{CB}=45V$ $I_E=0$		20 20	nA
Emitter cut-off current	$I_{EBO}$	$V_{EB}=4V$ $I_C=0$		20	nA
DC current gain A/F B/G C/H	$h_{FE}$	$V_{CE}=10V$ $I_C=100\mu A$	35 50 80		
DC current gain A/F B/G C/H	$h_{FE}$	$V_{CE}=1V$ $I_C=10mA$	75 110 180		
DC current gain A/F B/G C/H	$h_{FE}$	$V_{CE}=1V$ $I_C=100mA$	100 160 250	250 400 630	
Collector-emitter saturation voltage	$V_{CE(sat)}$	$I_C=100mA$ $I_B=10mA$ $I_C=500mA$ $I_B=50mA$		0.3 0.7	V
Base-emitter saturation voltage	$V_{BE(sat)}$	$I_C=100mA$ $I_B=10mA$ $I_C=500mA$ $I_B=50mA$		1.25 2	V
Transition frequency	$f_T$	$V_{CE}=5V$ $I_C=50mA$ $f=20MHz$	170		MHz

**NPN General Purpose Amplifier**

**BCW65/66**

TYPICAL CHARACTERISTICS @  $T_a=25^\circ\text{C}$  unless otherwise specified

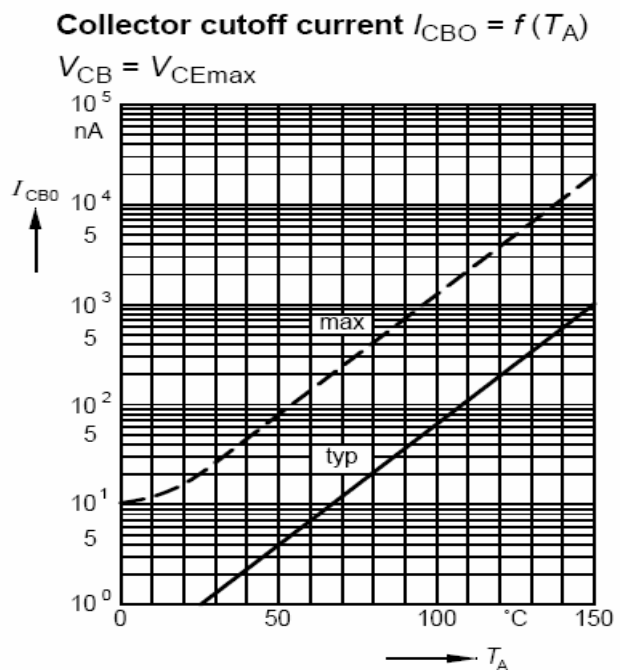
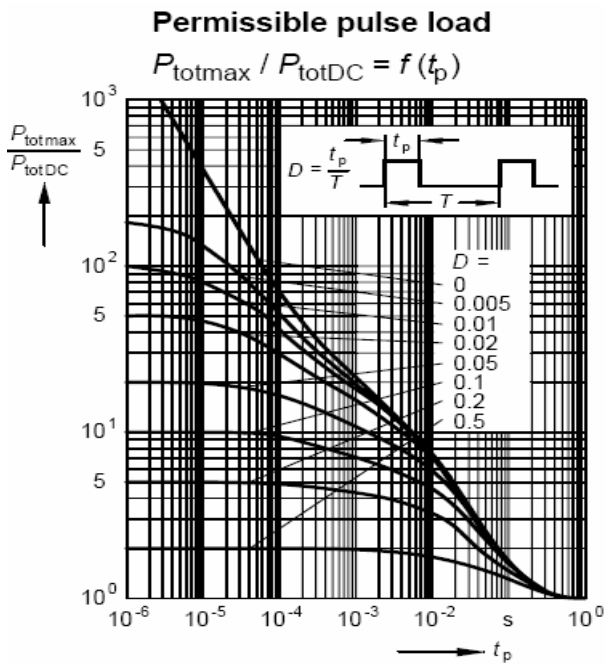
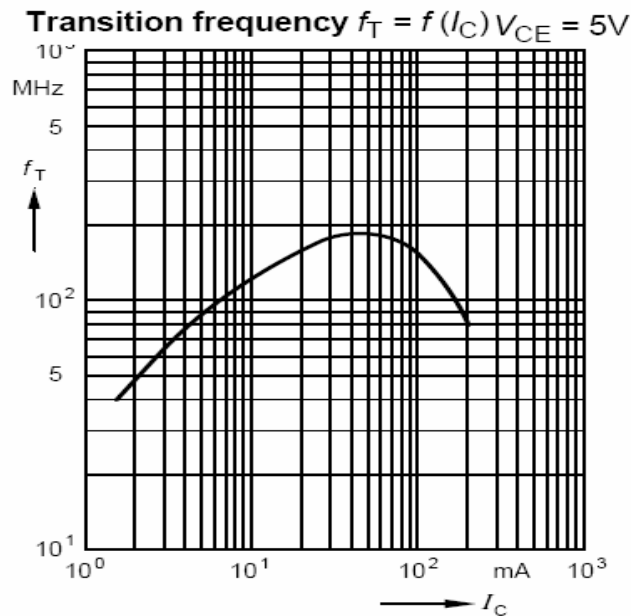
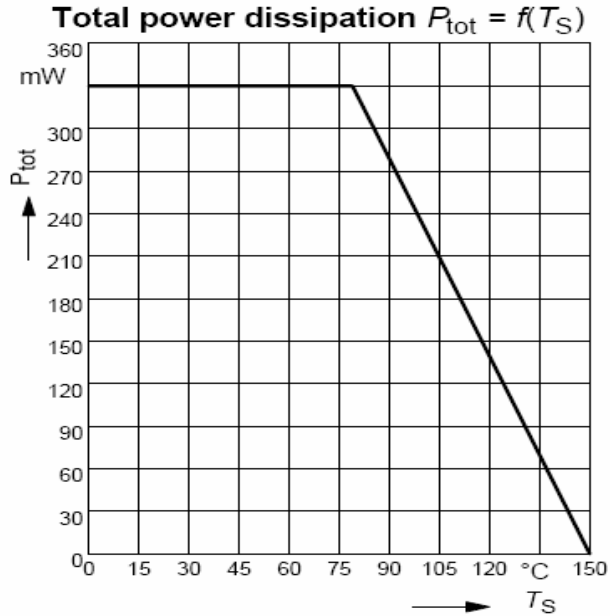



# NPN General Purpose Amplifier

# BCW65/66

### Base-emitter saturation voltage

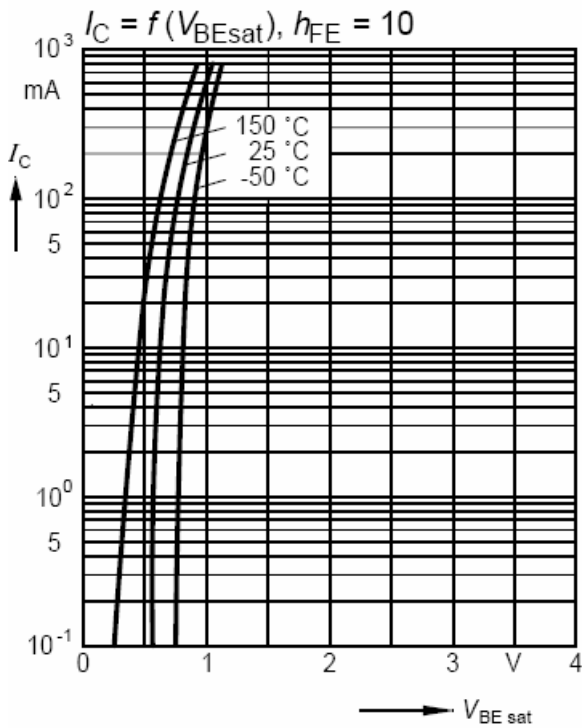

### Collector-emitter saturation voltage

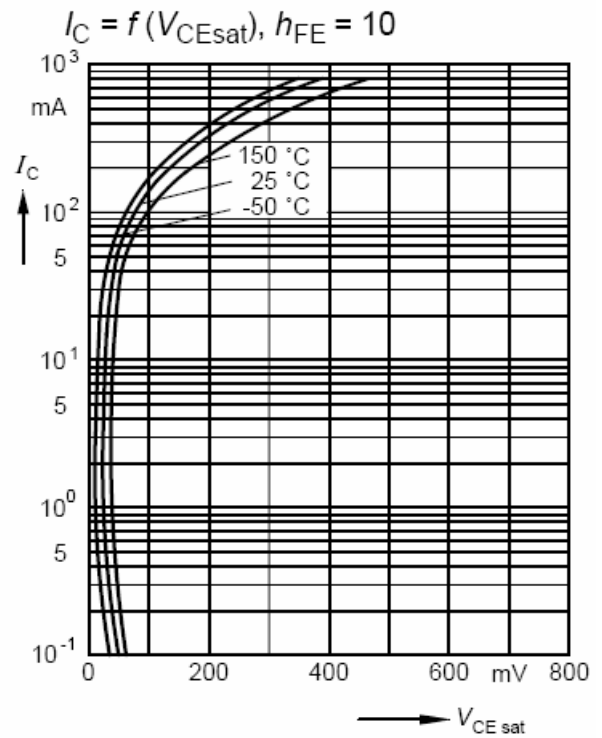

## NPN General Purpose Amplifier

## BCW65/66

### PACKAGE OUTLINE

Plastic surface mounted package

SOT-23

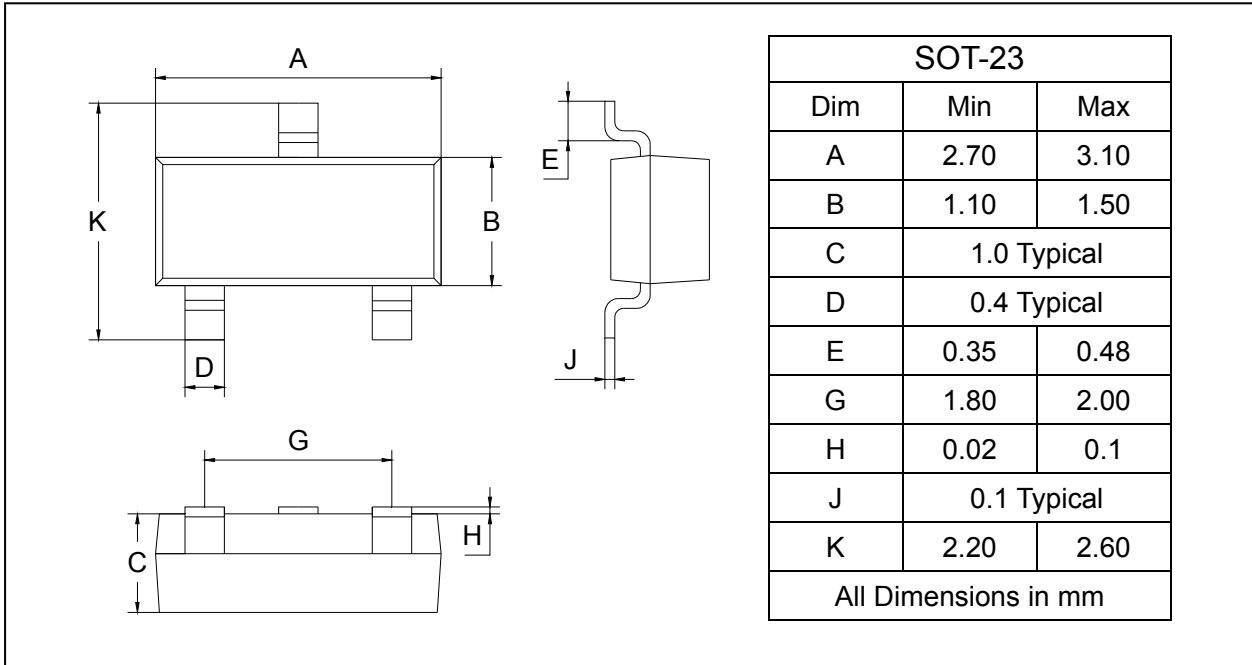

### SOLDERING FOOTPRINT

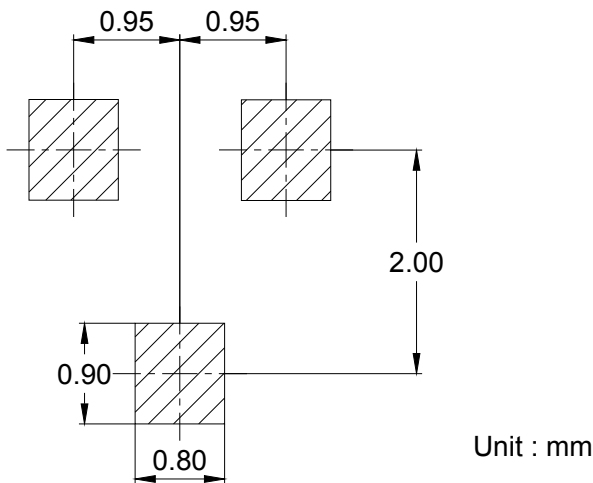

### PACKAGE INFORMATION

Device	Package	Shipping
BCW65/66	SOT-23	3000/Tape&Reel